

**ADDENDUM NO. 1**  
**LEWIS AND CLARK COUNTY FUELING AND MG/CL SYSTEMS**

**ADDENDUM DATE: NOVEMBER 22, 2024**

**NOTICE TO ALL BIDDERS**

The Contract Documents, Plans and Specifications are hereby modified as follows, and in submitting their bid, each bidder shall acknowledge receipt of all addenda which will become part of the Contract Documents.

**SECTION 00100 – INVITATION TO BID**

Page 1 of 2, change the third paragraph to read as follows:

“Sealed bids must be delivered to the Lewis and Clark County Commissioner’s Office, 316 N. Park Ave., Room 345, Helena, MT 59623 on or before 4:00 PM local time on Wednesday, December 11, 2024. The envelope containing the sealed bids must be labeled, “Fueling and Mg/Cl Systems”, Bid Enclosed.” Responsive bids will be unsealed publicly and read aloud on Thursday, December 12, 2024 at 9:00 am in Room 330 of the City-County Administrative Building, 316 N. Park Avenue, Helena, MT.”

**AGREEMENT BETWEEN OWNER AND CONTRACTOR FOR CONSTRUCTION CONTRACT**

Page 1 of 8, Article 4.02.A; change to contract time from “60 days” to “75 days”.

**DIVISION 1 – GENERAL REQUIREMENTS**

SECTION 01275 – MEASUREMENT AND PAYMENT, page 9 of 13, paragraph 3.1.R.2.a; change “schedule 40 PVC” to “schedule 80 PVC”.

**DIVISION 13 – SPECIAL CONSTRUCTION**

SECTION 13215 – CROSS LINKED POLYETHYLENE TANKS, page 4 of 7, paragraph 2.1.A; list “Snyder Industries, Inc.” as an approved tank manufacturer.

## **CONSTRUCTION PLANS**

- Cover Sheet: For the Base Bid scope of work description, change “Schedule 40 PVC” to “Schedule 80 PVC” for the ninth bullet point under Item No. 2 (Mg/Cl System).
- Sheet C3: Demolition Note No. 1; delete the second sentence in its entirety. Sludge removal from the existing fuel tanks will not be required.
- Sheet C3: Demolition Note No. 3; add the following sentence:

“The existing light poles are cast into the fueling area concrete slab. The contractor shall cut the poles flush with the concrete”
- Sheet C3: Demolition Note No. 5; add the following sentence:

“The downtime for fueling capability at the facility shall be limited to no more than one week.”
- Sheet C5: The two existing light poles that will be relocated to the new fueling area do not currently have base plates. Attached to this addendum is a detail for welding on base plates and for the new concrete foundations.
- Sheet C6: Construction Note No. 1; change “Schedule 40 PVC” to “Schedule 80 PVC”.
- Sheet E6: Detail 3/E6; stub-out and cap a blank conduit 3 feet beyond the concrete foundations for the gate keypads for future intercom cabling.

## **ACKNOWLEDGEMENT OF ADDENDUM NO. ONE (1)**

The bidder shall acknowledge receipt of Addendum No. One (1) on the Bid Form and Envelope.

**END OF ADDENDUM NO. 1**

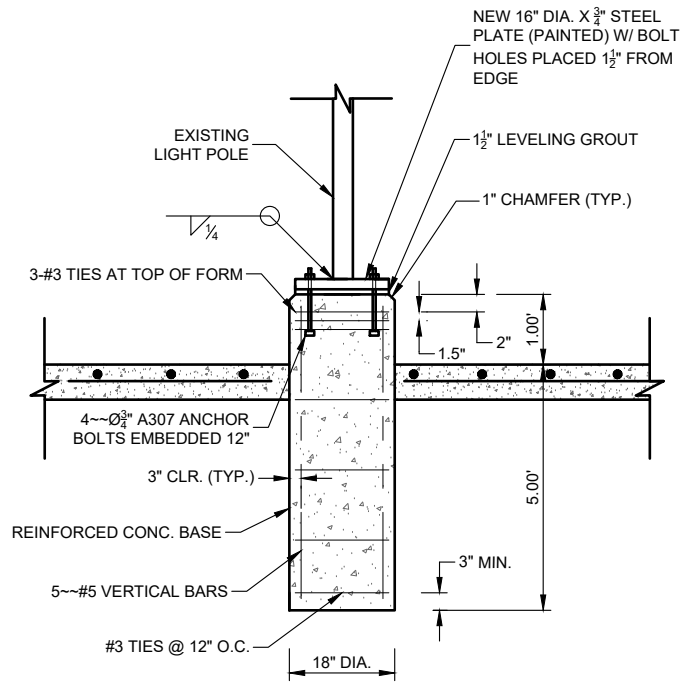

**LIGHT POLE BASE**

**LIGHT POLE DETAIL**